

Hanish

Water

MASTEK

A Brand By



HW-520-BG-1-P3
BioGuard-1

HW-520-BG-1-P3 BioGuard-1

Hanish Water

TM

MODEL HW-520-BG-1-P3
DIMENSIONS: 26 H, 9 D, 14 W"
VESSEL SIZES: 1-5x20"
VESSEL VOLUMES: .25 Gallons
DRY WEIGHT: 20 Lbs.
CONNECTIONS: 1" IN/OUT

Hartland, Wisconsin, U.S.A.



OPERATING SPECIFICATIONS

Minimum Operating Pressure	10 psi
Maximum Operating Pressure	100 psi
Test Pressure	160 psi
Maximum Operating Temperature	100 F
Minimum Operating Temperature	40 F
Maximum Flow Rate	40 gpm
Minimum Flow Rate	.1 gpm
Silica	1 mg/L
Copper	1.3 mg/L
Iron	.3 mg/L
Ph	6.8 – 8.5

DO NOT EXCEED SPECIFICATIONS

**Vessels approved for water filtration.
Other applications must be approved
by the manufacturer. Do not use for
pneumatic or hydropneumatic
applications.**

w w w . h a n i s h w a t e r . c o m

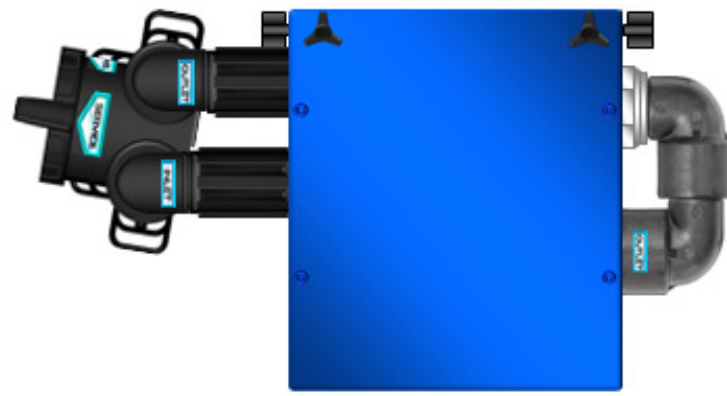

14"

9"

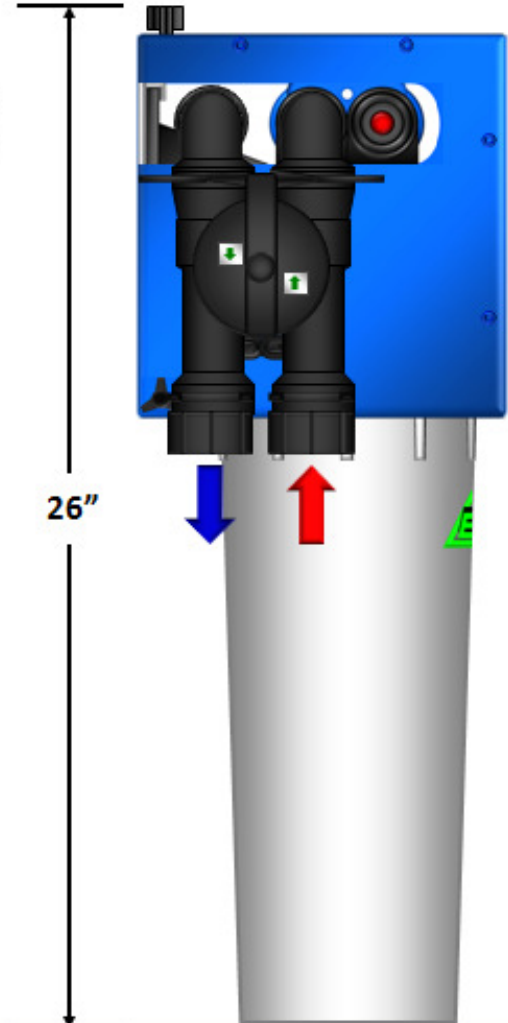
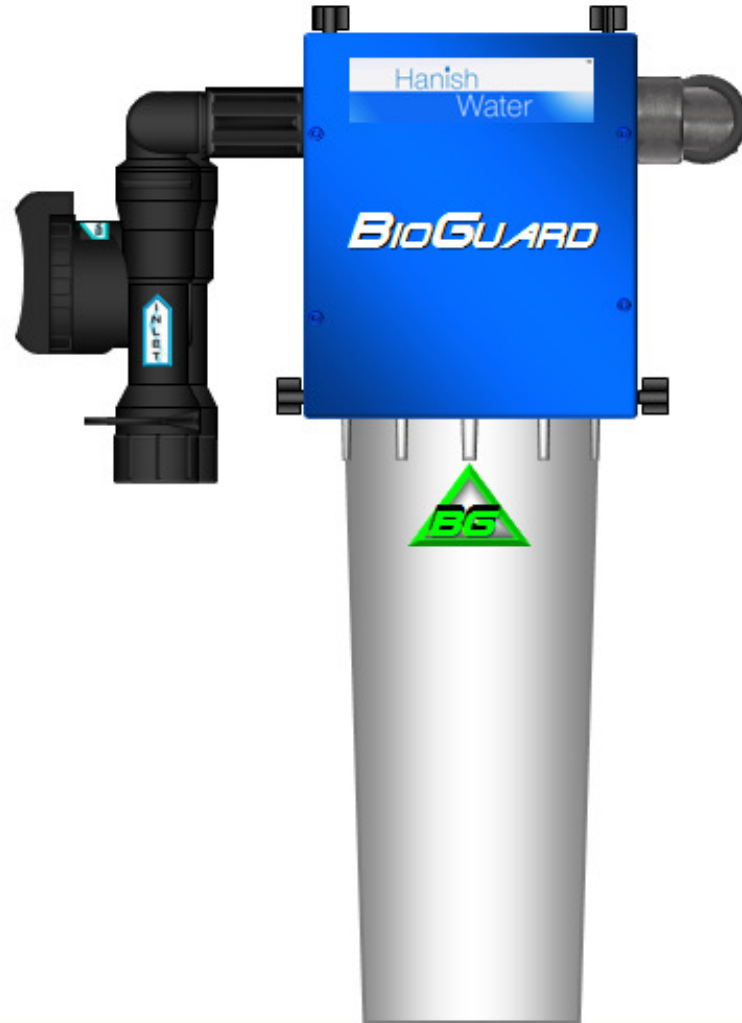

26"